

determined experimentally and which are quite independent of any measurement of surface tension.

4. These curves are found to agree with the analogous experimental curves.

5. The ring method may thus be considered an absolute one for the determination of surface tension.

CHICAGO, ILLINOIS

[CONTRIBUTION FROM FERTILIZER AND FIXED NITROGEN INVESTIGATIONS, BUREAU OF CHEMISTRY AND SOILS]

EQUILIBRIUM IN THE SYSTEM $\text{Co}-\text{CO}_2-\text{CoO}-\text{CO}$. INDIRECT CALCULATION OF THE WATER GAS EQUILIBRIUM CONSTANT

BY P. H. EMMETT AND J. F. SHULTZ

RECEIVED DECEMBER 19, 1929

PUBLISHED MAY 8, 1930

Introduction

A survey of the literature reveals marked disagreement concerning the value of the equilibrium constant K_1 for the reaction

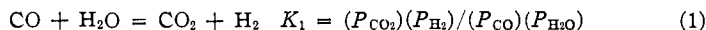

Hahn,¹ Haber and Richardt,² and finally Neumann and Köhler³ have obtained directly values for the equilibrium constant. However, Eastman⁴ and his collaborators, by measuring the equilibrium in each of the reactions

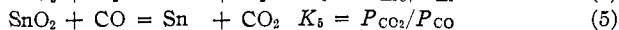
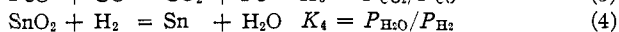
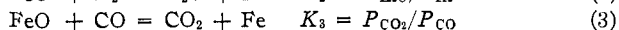
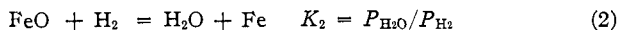

and by making use of the relations $K_1 = K_3 / K_2 = K_5 / K_4$, obtain indirectly a value for the water gas equilibrium constant that differs by about 40% from the directly determined one. The evidence for the validity of the indirect calculation has seemed particularly strong in view of the fact that the results obtained in the Sn-SnO₂ system agree so excellently with those in the Fe-FeO system. Accordingly, since we have already determined and published⁵ the value of the equilibrium constant for the reaction

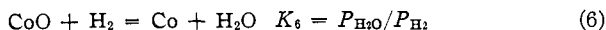

¹ Hahn, *Z. physik. Chem.*, **44**, 513 (1903); **48**, 735 (1904).

² Haber and Richardt, *Z. anorg. Chem.*, **38**, 5 (1904).

³ Neumann and Köhler, *Z. Elektrochem.*, **34**, 218 (1928).

⁴ (a) Eastman and Evans, *THIS JOURNAL*, **46**, 888 (1924); (b) Eastman and Robinson, *ibid.*, **50**, 1106 (1928).

⁵ Emmett and Shultz, *ibid.*, **51**, 3249 (1929).

it seemed of interest to determine experimentally the equilibrium constant for the reaction

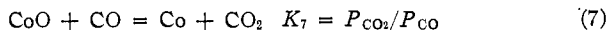

and thus to obtain an additional set of data from which the water gas equilibrium constant could be calculated.

Experimental

A flow method similar to that described in the previous paper⁵ was used in the present experiments. It consisted in passing known carbon dioxide-carbon monoxide mixtures over a large volume of catalyst held at constant temperature and determining the CO_2 -CO ratio in the effluent gas. Equilibrium was approached from both the high and low CO_2/CO sides at each temperature; readings were continued until a constant and reproducible value was obtained.

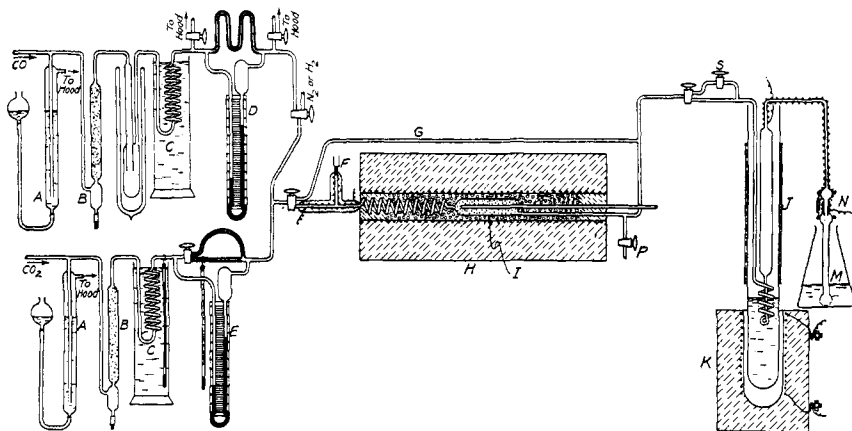

Fig. 1.

The apparatus can best be described with the help of Fig. 1. Commercial carbon dioxide, after being dried by phosphorus pentoxide, was passed through a flowmeter into the catalyst chamber. Carbon monoxide, especially prepared by Thompson in a manner already described,⁶ was passed through a liquid-air trap to free it from $\text{Fe}(\text{CO})_5$, which experience has shown is likely to accumulate when, as in the present case, the carbon monoxide had been stored for some time in a steel cylinder. The carbon monoxide was then passed through a flowmeter into the catalyst chamber. Necessary overflow bubblers as well as means of conducting to hoods any excess carbon monoxide were also employed as shown. The furnace was the same as that previously used and consisted of a nichrome wound alundum tube packed into a larger iron cylinder with "85% magnesia." The reaction chamber was packed into the center of the alundum tube with mossy copper. A thermocouple well extending along the axis of the glass reaction tube permitted the temperature to be measured throughout the entire length of the Co-CoO mass. The gradient thus obtained did not exceed 3° . The temperature was measured with a calibrated alumel-chromel thermocouple, together with a portable

⁶ Thompson, *Ind. Eng. Chem.*, **21**, 389-390 (1929).

Leeds and Northrup potentiometer indicator. The cold junction correction on the instrument was set correctly several times each day.

In the course of the experiments, streams of pure hydrogen, pure nitrogen and steam were required. Separate stopcocks connected the system to supplies of nitrogen and of hydrogen that had each been purified by passage over hot copper. The steam boiler was sealed off when not needed.

The carbon dioxide flow was measured by means of a carefully calibrated flowmeter. Two methods of calibration were used to avoid any uncertainty as to the rate of carbon dioxide passage. The flowmeter was first calibrated by collecting the carbon dioxide over a saturated sodium chloride solution. Many points were obtained at several flows varying from 10 to 100 cc. of the gas per minute. This calibration curve was checked by a second method that consisted in absorbing the stream of carbon dioxide in a potassium hydroxide weighing bulb and noting the increase in weight per unit time for a given setting of the flowmeter. The agreement obtained in the two calibrations is shown in Table I. In actual runs only flowmeter settings were used for which the calibrations in Table I were made.

TABLE I
CALIBRATION OF CARBON DIOXIDE FLOWMETER

	Small capillary		Large capillary		
	Height of flowmeter liquid, cm.	11.0	27.6	9.0	10.8
Cc./min., Method 1 ^a	10.26	25.75	50.41	60.56	101.29
Cc./min., Method 2 ^b	10.33	25.94	50.05	60.17	100.22
Cc./min., average of 1 and 2	10.30	25.85	50.23	60.37	100.76

^a Carbon dioxide was collected in potassium hydroxide and weighed.

^b Carbon dioxide was collected over saturated sodium chloride solution and the displaced liquid measured.

The carbon monoxide content of the exit carbon dioxide-carbon monoxide mixture was determined by passage over iodine pentoxide, absorption of the liberated iodine in potassium iodide solution, and titration with 0.001 *N* sodium thiosulfate solution.⁷ An approximate entering flow of carbon monoxide was obtained by a flowmeter equipped with a capillary sufficiently small in diameter to permit the passage of only 6 or 7 cc. of carbon monoxide per minute, under a head of 40 cm. of Nujol.

The 0.001 *N* sodium thiosulfate was standardized by titration against carefully checked 0.00121 *N* potassium permanganate solution. The agreement obtained as shown in Table II between the titrated carbon monoxide and measured carbon monoxide in calibration of the carbon monoxide flowmeter serves as an additional check of the fact that the titrimetric carbon monoxide determination could not be grossly in error. The normality of the thiosulfate was checked daily. The efficiency of the iodine pentoxide toward the oxidation of carbon monoxide was determined at frequent intervals by running blanks on the entering CO₂-CO ratios. In addition, a final check of the efficiency of the iodine pentoxide was obtained at the end of the series of equilibrium measurements by comparing the efficiency of the iodine pentoxide tube held at 100° with that of two iodine pentoxide tubes in series, the first at 100° and the second at 140°. The agreement of the carbon monoxide as determined in these experiments is shown in Table II. It was considered sufficient proof that all carbon monoxide was being quantitatively oxidized to carbon dioxide by the iodine pentoxide in the equilibrium runs.

For the small concentrations of carbon monoxide used in the present experiments it was found entirely satisfactory to maintain the iodine pentoxide at a temperature of

⁷ Vandaveer and Gregg, *Ind. Eng. Chem., Analytical Ed.*, 1, 129 (1929).

TABLE II
 CALIBRATION DATA

 Height of flowmeter liquid, 2.35 cm.; inlet CO,^a 0.30 cc./min.; time, 5 min.

Cc. Na ₂ S ₂ O ₃	Exit CO Total	Exit CO cc./min.	Cc. Na ₂ S ₂ O ₃	Exit CO Total	Exit CO cc./min.
One I ₂ O ₅ tube at 100°			Two I ₂ O ₅ tubes in series: Tube 1 at 100°; Tube 2 at 140°		
26.03	1.482	0.296	25.76	1.466	0.293
25.70	1.463	.292	25.86	1.471	.294
26.20	1.491	.298	25.85	1.470	.294
26.11	1.485	.297	25.70	1.463	.292

^a These "inlet CO" flows were taken from an extrapolated calibration curve obtained by measuring volumetrically the carbon monoxide at flows of five and ten cc. per minute. It should be accurate to 5%.

100°. Quantitative oxidation of the carbon monoxide with liberation of iodine was thereby obtained without causing any thermal decomposition of the pure iodine pentoxide. Stopcock S was adjusted to produce the same back pressure in the line during the intervals between runs that was produced by the potassium iodide absorption solution during a run. Thus by turning the gas stream through S during the interval between runs a practically constant rate of flow could be produced.

The exit of the iodine pentoxide tube was electrically heated in order to prevent the condensation of iodine. A ground-glass joint was provided in the exit line permitting the portion dipping into the potassium iodide solution to be removed and washed free of any condensed iodine. By such means all traces of iodine evolved in a particular run could be washed into the potassium iodide solution and titrated.

The cobaltous oxide used in the present experiment was the same sample that had been used in a previous determination of the steam-hydrogen equilibrium over cobalt-cobaltous oxide already referred to.⁵ It was originally prepared by igniting to 500° some recrystallized cobaltous nitrate containing 0.98% of nickel, reducing this material almost completely with hydrogen, and partially reoxidizing it to cobaltous oxide by a long steaming process at 500°. Its weight as Co₃O₄, at the completion of the ignition in air, was 23 g. Its apparent volume was 30 cc.

At the beginning of the series of runs the cobalt-cobaltous oxide mixture was steamed at 500° until 75% oxidized. Then about 400 cc. of hydrogen was passed through to insure the presence of ample cobalt surface. The hydrogen-steam mixture was removed by flushing with nitrogen. At each of the three temperatures studied, carbon dioxide-carbon monoxide mixtures were passed over the resulting material at such rates of flow as were necessary to obtain equilibrium. From time to time the surface of metallic cobalt was restored by reduction with about 400 cc. of hydrogen. Equilibrium was approached from both sides and readings were taken over a sufficient interval of time to assure the reaching of steady state conditions and to exclude the possibility of temporary surface effects influencing the equilibrium values. In each run readings were taken of the temperature of the air immediately surrounding the capillary of the carbon dioxide flowmeter, temperature of the water-bath through which the carbon dioxide line passed before reaching the capillary, temperature of the reaction tube, time of passage of carbon dioxide, barometric pressure, and back pressure in the reaction system resulting from placing potassium iodide absorption solution on the exit of the iodine pentoxide tube. The volume of carbon monoxide as determined by the thiosulfate titration was also recorded. The CO₂-CO ratio in equilibrium with Co-CoO at each of the three temperatures employed was calculated from these data.

Experimental Results

The values of $K_7 = P_{\text{CO}_2}/P_{\text{CO}}$ obtained at 450, 515 and 570° are 489.6, 245.9 and 148.4, respectively. Attempts to obtain values at 330° were abandoned because of the sluggishness with which equilibrium was reached at so low a temperature.

In Tables III, IV and V are shown a few typical runs at each of the three temperatures studied. They consist of several groups of consecutive runs taken from a longer series of runs at each of the temperatures. In Col. 2 is

TABLE III
DATA FROM TYPICAL RUNS. TEMPERATURE, 450°

Run no.	Inlet mixture		Time, sec.	Exit CO, total cc.	CO ₂ /CO	
	CO ₂ , cc./min.	CO, cc./min.			Inlet	Exit
143	25.80	0	600	0.523	∞	492.4
144	25.85	0	600	.521	∞	494.8
145	25.88	0	600	.522	∞	494.8
154	100.86	0.31	300	1.051	325.3	480.3
155	101.22	.31	300	1.057	326.5	479.3
156	100.80	.31	300	1.045	325.1	482.8

TABLE IV
DATA FROM TYPICAL RUNS. TEMPERATURE, 515°

Run no.	Inlet mixture		Time, sec.	Exit CO, total cc.	CO ₂ /CO	
	CO ₂ , cc./min.	CO, cc./min.			Inlet	Exit
168	60.03	0.31	300	1.223	193.6	245.7
169	60.03	.31	300	1.217	193.6	246.9
170	60.03	.31	300	1.235	193.6	243.3
197	25.55	0	600	1.021	∞	249.3
198	25.47	0	600	1.026	∞	247.3
201	25.40	0	600	1.033	∞	244.9
202	25.40	0	600	1.037	∞	244.0
203	10.10	0	600	0.412	∞	244.2
204	10.12	0	600	.415	∞	242.8

TABLE V
DATA FROM TYPICAL RUNS. TEMPERATURE, 570°

Run no.	Inlet mixture		Time, sec.	Exit CO, total cc.	CO ₂ /CO	
	CO ₂ , cc./min.	CO, cc./min.			Inlet	Exit
214	25.58	0	600	1.724	∞	147.4
215	25.54	0	600	1.726	∞	147.0
216	25.55	0	600	1.716	∞	147.9
217	25.57	0	600	1.715	∞	148.1
218	25.59	0	600	1.720	∞	147.8
225	102.77	0.99	180	2.077	103.8	148.8
226	102.69	.99	180	2.082	103.7	148.3
227	102.81	.99	180	2.108	103.8	146.7
228	102.56	.90	180	2.053	113.9	150.1
229	102.50	.90	180	2.057	113.8	149.8
230	102.56	.90	180	2.061	113.9	149.5
231	102.39	.90	180	2.059	113.7	149.4

listed the rate of flow of carbon dioxide (S. T. P.) per minute into the reaction vessel. Corrections have been applied as explained later for the temperature of the flowmeter capillary and for the barometric pressure. Column 3 contains the approximate values for the entering flow of carbon monoxide, obtained as described in the footnote to Table II. Column 4 represents the time during which an analytical sample was taken. The total carbon monoxide shown in Col. 5 is that calculated from titration with the sodium thio-sulfate. The average of the exit CO_2/CO ratios in Col. 6 of the tables differs slightly from the average of all runs made. This is inevitable, of course, in choosing only a small number of representative runs out of a large number taken.

It was noticed in the course of the work that the first few runs made after a reduction of the oxide surface by hydrogen yielded low values for the CO_2 - CO ratio, when pure carbon dioxide was passed over the oxide-metal mixture. Furthermore, the first few runs made after complete oxidation of the surface to cobaltous oxide yielded abnormally high CO_2/CO values, even though the entering CO_2 - CO ratio was much less than the normal equilibrium value. Figure 2 gives a few typical curves illustrating this latter effect. In each instance the entering CO_2 - CO ratio was 30 to 50% less than the normal equilibrium value. The value of K_7 decreases with time until the normal value results. This is entirely analogous to the effect noted in the determination of the H_2O - H_2 ratio necessary to oxidize cobalt to cobalt oxide.⁵

The accuracy of the above equilibrium values will depend upon the reliability of the volume of carbon dioxide passing the reaction tube per unit time, the volume of carbon monoxide passing the reaction tube in the same time and the temperature of the reacting cobalt-cobaltous oxide.

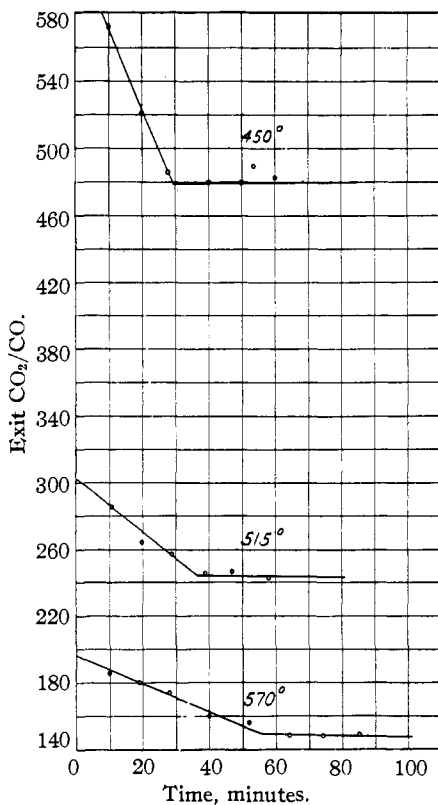

Fig. 2.—Typical curves showing the effect of "surface oxide" on the CO_2 - CO equilibrium value. The three series of runs shown were taken immediately after oxidation of the cobalt surface to CoO . The entering CO_2 - CO ratios in the 570, 515 and 450° runs shown were 102, 194 and 325, respectively.

Accordingly, each of these determinations will be briefly considered with a view to fixing the maximum and probable errors of the final equilibrium values.

Four possible sources of error in the determination of the carbon dioxide are (1) the uncertainty in corrections for the pressure and temperature variations from the temperature and pressure at which the flowmeter was originally calibrated; (2) the reading error on the flowmeter; (3) the uncertainty in the calibration of the flowmeter; and (4) the uncertainty of the exact temperature of the flowmeter capillary through which the carbon dioxide passed. The first of these sources of error was corrected for by the equation

$$\frac{V_1}{V_2} = \frac{\eta_2 T_2 P_1}{\eta_1 T_1 P_2}$$

where V_1 is the volume of gas (S. T. P.) that passed the flowmeter during calibration when the height of the flowmeter liquid was h_1 , the capillary of the flowmeter was at T_1 and the pressure at the exit of the flowmeter P_1 ; η_1 is viscosity of carbon dioxide at T_1 ; V_2 is volume of gas (S. T. P.) passing the capillary when the latter is at T_2 , the pressure at the flowmeter exit P_2 and the height of the flowmeter liquid again h_1 ; η_2 is viscosity of carbon dioxide at T_2 .

The values for the viscosity of carbon dioxide in the "International Critical Tables" (Vol. V, p. 4) are 147.1 at 23° and 137 at 0°. In making corrections by the above formula, η_2 and η_1 were obtained by extrapolating these viscosity values to the temperature range 25–33°, over which the capillary varied during the series of runs. When, as in the above measurements, T_1 is 29°, P_1 is 750 mm., $(T_1 - T_2) \bar{\approx} 4^\circ$ in absolute value, and $P_1 - P_2 \bar{\approx} 10$ mm. in absolute value, it is believed the uncertainties of this correction should be very small, probably $\approx 0.2\%$. (2) The uncertainty of the flowmeter reading will not exceed 1 mm. This represents an error of $\approx 0.6\%$ at the rates of flow used for most of the runs. (3) From the calibration data of Table I the uncertainty of the carbon dioxide calibration seems to be about $\approx 0.3\%$. (4) It is assumed that the temperature of the capillary of the flowmeter does not differ by more than $\approx 0.5^\circ$ from that of the thermometer hanging in air beside it. The summation of the possible errors in the carbon dioxide values thus amounts to $\approx 1.3\%$.

The two sources of error in the carbon monoxide determination are the series of standardization determinations against potassium permanganate and the individual titration in each regular run. The first of these seems not to exceed $\approx 0.3\%$. Assuming the end-point in the final thio-sulfate-iodine titration to be accurate to ≈ 0.2 cc., a maximum error of about $\approx 1.2\%$ would result. Hence the maximum individual error in the carbon monoxide determinations was about $\approx 1.5\%$.

From a plot of the logarithm of the equilibrium constant against the reciprocal of the absolute temperature, the variation of each constant per degree of temperature variation is readily found to amount to approximately 1% per degree. The temperature was noted at the beginning and end of each run and an average value recorded. The portable potentiometer could be read to $\pm 1^\circ$. It is probable, therefore, that errors due to temperature variation did not exceed $\pm 1\%$. However, in the present maximum error calculation an uncertainty in temperature of $\pm 3^\circ$ causing a possible error of $\pm 3\%$ in the equilibrium constants for any specified temperature has been assumed.

The summation of the maximum errors that could conceivably be involved in any one reading is thus about 6%. An examination of all the data obtained, however, shows that the maximum deviation from the mean was very much smaller than this calculated possible maximum error. In fact, the maximum deviation of any one reading from the average was 3.9% at 570°, 3.6% at 515° and 2% at 450°. The average deviation was between 1 and 1.3% for the three temperatures. Probable errors calculated by the usual formula on a basis of all of the readings obtained at each temperature (except, of course, those immediately following fresh reduction or oxidation of the catalyst surface) amount to about $\pm 0.3\%$.

The Equilibrium Constant for the Water Gas Reaction.—The values of K_6 already reported⁵ for the temperatures 450, 515 and 570° are 67, 57.5 and 50.3, respectively. From the above K_6 values and the K_7 values determined in the present work, the values of $K_1 = (P_{\text{CO}_2})(P_{\text{H}_2})/(P_{\text{CO}})(P_{\text{H}_2\text{O}})$ can be readily calculated to be 7.31, 4.31 and 2.94 at 450, 515 and 570°, respectively. Most workers have expressed their results in terms of $K_{\text{wg}} = 1/K_1$. The present calculated values of K_{wg} are accordingly the reciprocals of the above and equal to 0.137, 0.232 and 0.340 at the above temperatures. These values agree closely with 0.140, 0.232 and 0.345 obtained in the direct measurements of Neuman and Köhler. In Fig. 3 are plotted values for $\log K_{\text{wg}}$ against $1/T$. The results of the direct determination of K_{wg} by Hahn,¹ by Haber and Richardt² and by Neumann and Köhler³ are included for comparison. The indirectly determined values of Eastman and Evans^{4a} are also indicated.

A consideration of the maximum errors that could reasonably be included in the equilibrium values both in the system $\text{Co-H}_2\text{O-CoO-H}_2$ and the system $\text{Co-CO}_2\text{-CoO-CO}$ indicates that the excellent agreement between the values of the water gas constant indirectly determined with the help of Co-CoO mixtures and the directly determined values is truly significant and not a coincidence resulting from experimental error. Assuming a temperature reading accurate to $\pm 3^\circ$, and an error of $\pm 0.5\%$ in reading the hydrogen, the values given in the previous paper for the $\text{H}_2\text{O-H}_2$ ratio in equilibrium with cobalt-cobaltous oxide are accurate to

$\pm 1.5\%$. Accordingly, the summation of all the maximum errors for the two sets of experiments could not, it seems, exceed 7.5% . The probable errors, as calculated from all readings taken in both systems, total $\pm 0.5\%$. The conclusion seems warranted that the cobalt-cobaltous oxide system affords a reliable indirect means of obtaining values for the water gas constant. The reaction both with steam-hydrogen and with carbon dioxide-carbon monoxide is remarkably free from complications. No oxides other than cobaltous oxide are present, as was established by x-ray powder photographs of the samples used. Tests for carbon or carbide in the cobalt after

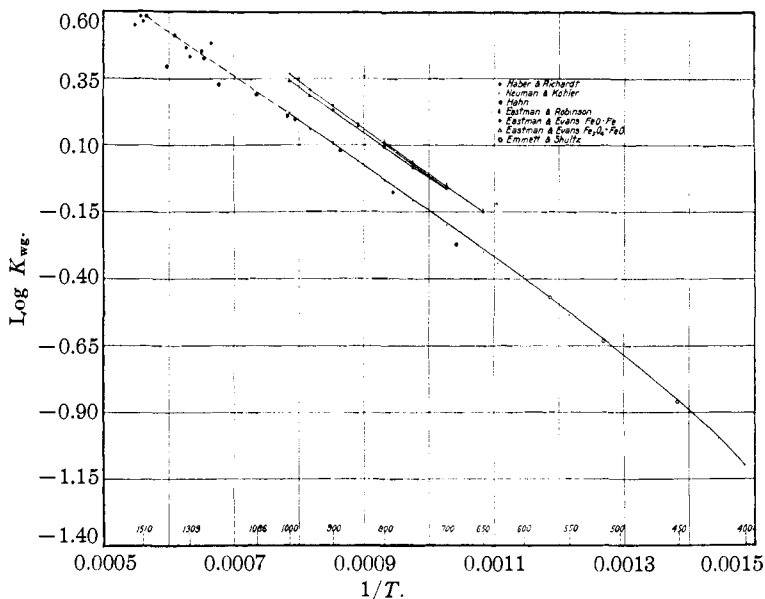

Fig. 3.—Variation with $1/T$ of $\log K_{wg}$ where $K_{wg} = (\text{CO})(\text{H}_2\text{O})/(\text{CO}_2)(\text{H}_2)$. The values of Haber and Richardt, Neumann and Köhler and Hahn are all directly measured values; those of the other authors are the indirect, calculated ones.

the carbon dioxide-carbon monoxide equilibrium were practically negative, 0.06% carbon only being found in each of two samples analyzed.

In view of the fact that the indirectly determined values of K_{wg} obtained from equilibria of Reactions 6 and 7 were calculated from experimental data obtained over the temperature range 450 to 570° , one cannot, strictly speaking, compare the values so obtained with those obtained by indirect means at higher temperatures. Since it does not seem reasonable, however, to expect sudden changes with temperature in the values of the equilibrium constants of Reactions 6 and 7, between 570 and 700° , one can conclude that the present indirectly determined values of K_{wg} not only verify the directly determined water gas values of Neumann and

Köhler below 570° , but also add a very considerable weight to their direct determinations at higher temperatures.

It is not the purpose of the present paper completely to review all of the other indirect determinations of the water gas equilibrium constant or to attempt therein to explain the discrepancies that now seem to exist. Nevertheless, a few observations will perhaps be worth while.

The experimental work of Eastman and Robinson^{4b} upon the determinations of the equilibria of Reactions 4 and 5 in the Sn-SnO₂ system seems

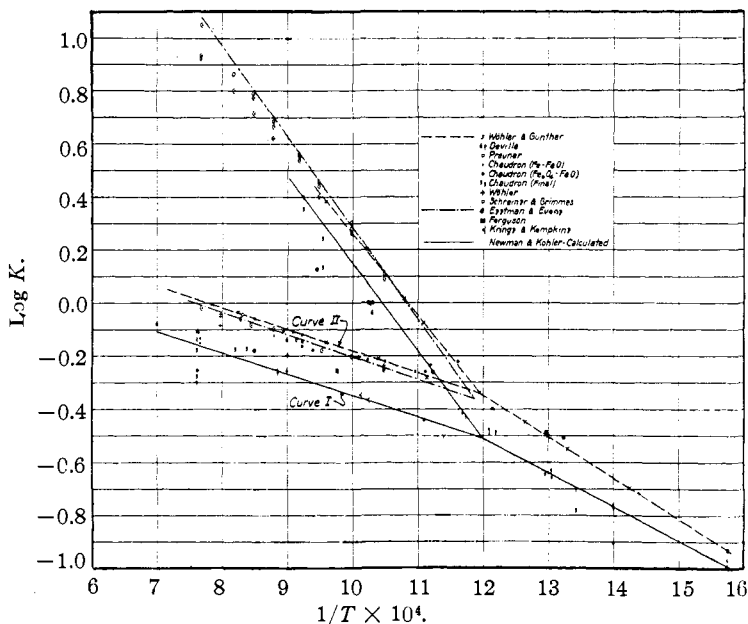

Fig. 4.—Variation with $1/T$ of $\log K$, where $K = (\text{H}_2\text{O})/(\text{H}_2)$ in equilibrium with FeO-Fe , $\text{FeO-Fe}_3\text{O}_4$ or $\text{Fe-Fe}_3\text{O}_4$. Curve I is calculated by combination of equilibrium constants for the Fe-C-O system and the direct water gas constants of Neumann and Köhler. Curve II is the experimental curve of Wöhler and Günther.

to have been carefully and accurately done. We are unable to suggest at present any plausible reason why the resulting indirectly calculated water gas constant should be in error. The fact that one of the phases involved in the two equilibria was a liquid and might possibly have been appreciably different in composition in Reaction 5 than in Reaction 4, due to possible dissolved tin carbide, or oxide, offers a slight but entirely unconfirmed source of difficulty.

It has seemed to us, however, that indirect calculation of the water gas constants involving the equilibrium constant for Reaction 2 are more open to question. In Fig. 4 are plotted the principal determinations that have

been made of the ratio of steam to hydrogen in equilibrium with Fe-FeO at various temperatures. Curve I has been calculated by combining the generally recognized best values for Reaction 3 as chosen by Eastman⁸ with the directly determined water gas equilibrium constants of Neumann and Köhler. Any experimental points for the steam-hydrogen equilibria of Reaction 2 will, assuming always the correctness of the Fe-C-O diagram of Eastman, give indirectly calculated values of the water gas constant in perfect agreement with the direct. It can be seen at a glance that the experimental values for the most part fall into two groups. Those of Chaudron,⁹ of Deville,¹⁰ of Preuner,¹¹ of Ferguson¹² and of Krings and Kempkens¹³ all agree fairly well with Curve I. The values of the other workers^{14,4a} shown in the diagram agree much more closely with Curve II drawn by Wöhler and Günther¹⁵ as a representative locus of their own experimental points. We believe it is especially significant that the recent experimental values for the equilibrium constant reported by Krings and Kempkens were obtained by a flow system and are in good agreement with Curve I. Work is now being carried on in this Laboratory to test a possible source of difficulty that has thus separated the experimental observations to date into the two groups. Further discussion of these results will accordingly be deferred to a later paper.

It seems, then, that a correct and fair statement concerning the value of the water gas equilibrium constant must admit of the following.

1. The direct determinations by Neumann and Köhler are in fair agreement with those of Hahn, and of Haber and Richardt. They seem to have been carefully done and are not open to any apparent sources of gross error.

2. The present indirect calculation of the water gas constant from the equilibria for the systems Co-H₂O-CoO-H₂ and Co-CO₂-CoO-CO at temperatures of 450 to 570° agrees well with the directly determined values of Neumann and Köhler. The solid phases seem free of solid solution effects and carbide formation. It is believed the agreement is real and significant.

3. The indirect calculation by Eastman and Robinson involving the Sn-SnO₂ equilibria of Reactions 4 and 6 give values about 40% higher than the directly determined values. No probable cause of the discrepancy is as yet apparent.

⁸ Eastman, *THIS JOURNAL*, **44**, 975 (1922).

⁹ Chaudron, *Compt. rend.*, **159**, 237 (1914); *Ann. chim. phys.*, **16**, 221 (1921).

¹⁰ Deville, *Compt. rend.*, **70**, 1105, 121 (1870); **71**, 30 (1871).

¹¹ Preuner, *Z. physik. Chem.*, **47**, 385 (1904).

¹² Ferguson, *J. Washington Acad. Sci.*, **13**, 275 (1923).

¹³ Krings and Kempkens, *Z. anorg. allgem. Chem.*, **183**, 225 (1929).

¹⁴ Wöhler and Balz, *Z. Elektrochem.*, **27**, 406 (1921); Schreiner and Grimes, *Z. anorg. Chem.*, **110**, 311 (1920).

¹⁵ Wöhler and Günther, *Z. Elektrochem.*, **29**, 276 (1923).

4. The indirect calculations involving the Fe-H₂O-H₂ equilibria fall principally into two groups, the one agreeing fairly well with the directly measured values, the other being some 40% higher.

Summary

The value of the equilibrium constant $K_7 = \text{CO}_2/\text{CO}$ for the reaction $\text{CoO} + \text{CO} = \text{Co} + \text{CO}_2$ has been determined by a flow system at 450, 515 and 570°, to be 489.6, 245.9 and 148.4, respectively. Combination of these values with the previously determined constant $K_6 = \text{H}_2\text{O}/\text{H}_2$ for the reaction $\text{CoO} + \text{H}_2 = \text{Co} + \text{H}_2\text{O}$ gives indirect values for the water gas constant $K_{\text{wg}} = (\text{CO})(\text{H}_2\text{O})/(\text{CO}_2)(\text{H}_2)$ that are in good agreement with the values determined directly by Neumann and Köhler. The present status of the disagreement between some of the indirectly determined values for K_{wg} and the direct values of Neumann and Köhler is summarized.

WASHINGTON, D. C.

[CONTRIBUTION FROM THE LABORATORIES OF THE ROCKEFELLER INSTITUTE FOR
MEDICAL RESEARCH]

A SCREENED BRIDGE FOR THE MEASUREMENT OF ELECTROLYTIC CONDUCTANCE. I. THEORY OF CAPACITY ERRORS. II. DESCRIPTION OF THE BRIDGE

By THEODORE SHEDLOVSKY

RECEIVED DECEMBER 26, 1929

PUBLISHED MAY 8, 1930

Introduction

Kohlrausch's classical method for measuring the electrical conductance of solutions has had the benefit of numerous improvements by many workers. The researches of Washburn¹ were particularly valuable in stimulating accurate conductance work in this country. Morgan and Lammert² have discussed some of the sources of error in the electrical arrangement used in the method, with valuable references to previous work. Of particular importance from the standpoint of precision measurements has been the comparatively recent introduction of vacuum tube alternating current generators and amplifiers for providing currents of symmetrical wave form, on the one hand, and increasing the sensitivity of the detector on the other.³ Jones and Josephs⁴ have described in a very detailed paper a direct reading alternating current bridge embodying these new features.

¹ Washburn and Bell, *THIS JOURNAL*, **35**, 177 (1913); Washburn, *ibid.*, **38**, 2431 (1916); Washburn and Parker, *ibid.*, **39**, 235 (1917).

² Morgan and Lammert, *ibid.*, **48**, 1220 (1926).

³ Hall and Adams, *ibid.*, **41**, 1523 (1919); Jones and Bollinger, *ibid.*, **51**, 2407 (1929).

⁴ Jones and Josephs, *ibid.*, **50**, 1049 (1928).